

Tow vehicle wiring for vans with Drum Brakes using Redarc 30/50 with ESC through Red Anderson

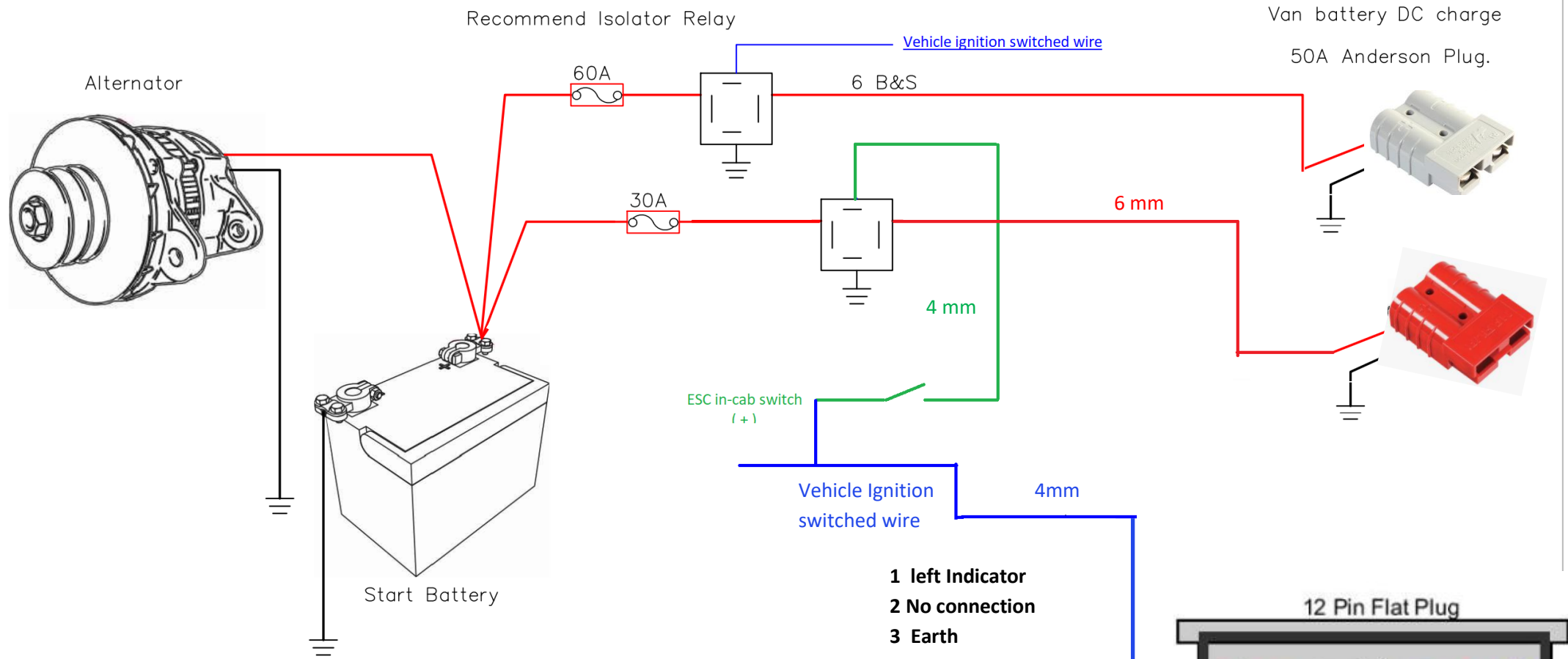

- The ESC is wired via 12 pin flat plug. Note the wiring configuration of the tow vehicle plug pins 10 and 11.
- Switch in vehicle required for ESC for ease of turning on/off when going between different terrains.
- Pin 12 requires a switched 12-volt positive feed from the vehicle's ignition for tow vehicle to be compatible with battery charging system and airbags.
- AOR recommends having all vehicle wiring carried out by a qualified auto electrician.

- 1 left Indicator
- 2 No connection
- 3 Earth
- 4 Right Indicator
- 5 Electric brake controller
- 6 Stop lights
- 7 Clearance lights
- 8 No connection
- 9 no connection
- 10 No connection
- 11 No connection
- 12 12 volt positive switched via Ignition

