

# Tow vehicle wiring for vans with Drum Brakes using Redarc 100 with ESC through Red Anderson

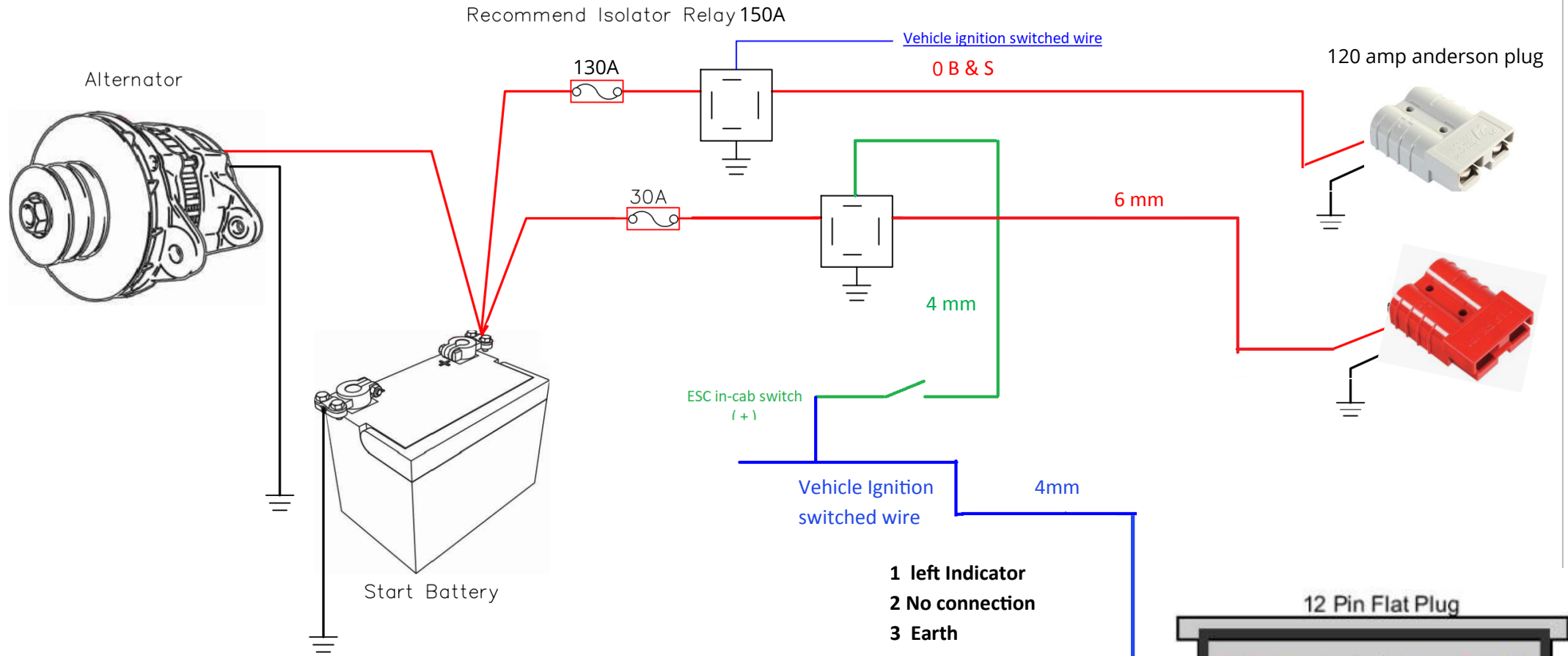

The ESC is wired via 12 pin flat plug. Note the wiring configuration of the tow vehicle plug pins 10 and 11.

Switch in vehicle required for ESC for ease of turning on/off when going between different terrains.

Pin 12 requires a switched 12-volt positive feed from the vehicle's ignition for tow vehicle to be compatible with battery charging system and airbags.

AOR recommends having all vehicle wiring carried out by a qualified auto electrician.

- 1 left Indicator
- 2 No connection
- 3 Earth
- 4 Right Indicator
- 5 Electric brake controller
- 6 Stop lights
- 7 Clearance lights
- 8 No connection
- 9 no connection
- 10 No connection
- 11 No connection
- 12 12 volt positive switched via Ignition

