

EVO5 Hydronic (Integrated Hot Water)



Installation & Operation Guide

General Information

Webasto Thermo & Comfort Australia Pty Ltd is pleased to provide this installation guide for the EVO5 Hydronic water and air heating system. When used according to the guidelines stated in this booklet, you should expect many years of trouble-free, enjoyable operation.

This installation guide represents our latest effort to produce the best technical documentation possible. In our efforts toward continuous, ongoing product improvement, we also encourage our customers to provide feedback concerning this guide and the EVO5 HYDRONIC heating system.

Visit our website for technical documents: www.webasto.com

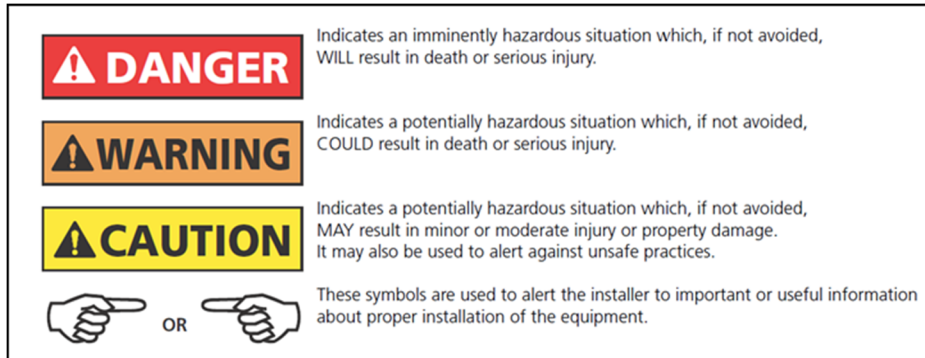

This Webasto Diesel Heater comes with a 2 year warranty.

Failure to follow these installation instructions and the notes contained therein will lead to all warranty being refused by Webasto Thermo & Comfort Australia Ltd Pty . The same applies if the repairs are carried out incorrectly or with use of parts other than genuine Webasto service parts. This will result in the voiding of all warranty. All service and repairs have to be carried out by authorised Webasto service dealers.

Purpose of the EVO5 Hydronic Heater

The Webasto EVO5 Hydronic heater is designed to heat water and air, and can be installed and used in camper trailers, caravans and motorhomes.

The heater operates independently of an engine and is connected to a fuel tank and the electrical system of the trailer/vehicle.

They are not designed to heat hazardous substances.

Pre-Installation Considerations

1. Location and orientation of the heater.
The heater may be fitted internally or externally to a vehicle. If it is installed externally ensure that the heater is fitted in a position where it is protected from water and dust ingress.
2. Location of the controller, electrical wiring, fuse and battery connections. (Plug & Play)
3. Location of the fuel pump and fuel filter.
4. Location of the exhaust and combustion air systems.
5. Location of fuel tank – 12L Webasto fuel tank. (Typically installed on the A frame).
6. Water pump flow rate to be max 10L/min.

Tips

Place the heater in your desired location to predetermine the mounting holes, exhaust system, wiring, controller, water connection hoses and general clearances for easy accessibility for service and repair.

Watermark

All EVO5 Hydronic components within the Webasto heated water service, that come into contact with drinking water, are Watermark compliant and certified.

AS 3498 / Certificate No. 23211

* Plate Heat Exchanger, Thermostatic Mixing Valve and Brass Fittings.



Serial Number Labelling

Ensure that the serial number labels are attached on the top or the side of the heater, in case the heater is mounted against a wall and the original label may be inaccessible. Additional labels are supplied in the kit and one should go on the installation manual envelope to hand over to the customer at the time of commissioning .



Fig 1 – Serial number labels – Heater

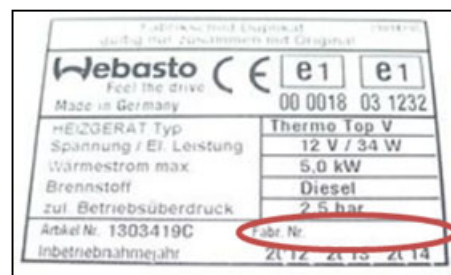

Fig 2 – Serial number label written as Fabr. Nr.

Note: In case of warranty situations, the serial number will be requested by Webasto or an authorised dealer to validate.

Product Registration

To commence the 2 year warranty the product should be registered on the Webasto Dealer Portal, if you do not have access, email the following information to: svc-WTAUtechnical@webasto.com

PRODUCT NAME & SERIAL NUMBER

VEHICLE MAKE, MODEL, VIN, YEAR & REGISTRATION NUMBER

END USER or MANUFACTURER SUBURB/TOWN & STATE/TERRITORY

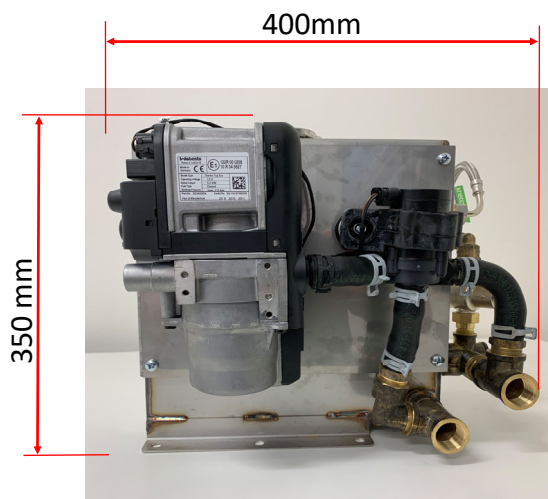
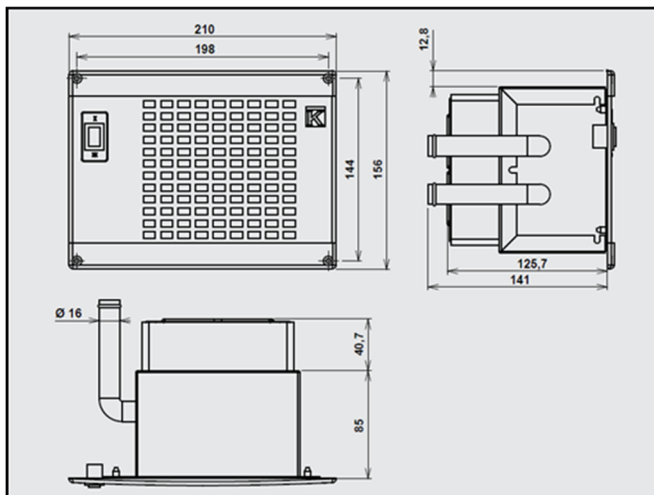

Fig 3 - With all installations, always allow clearance so the unit can be easily removed and installed in case of service and repair.



Calorific Power	1500 kcal/h
Heating Power	1.7 kW
Air Flow	110 m ³ /h
Power Consumption	7 W
Noise Level	48 dB
Weight	1 kg
Water Fitting	Ø 16 mm

Fig 4 - Remove the plugs on the inlet and outlet of the radiator fan heater before installing the hoses.
 Heater Mounting Cutout: 195 x 135 mm (L x H) x 170 mm depth clearance.

2. Hot Water System Layout

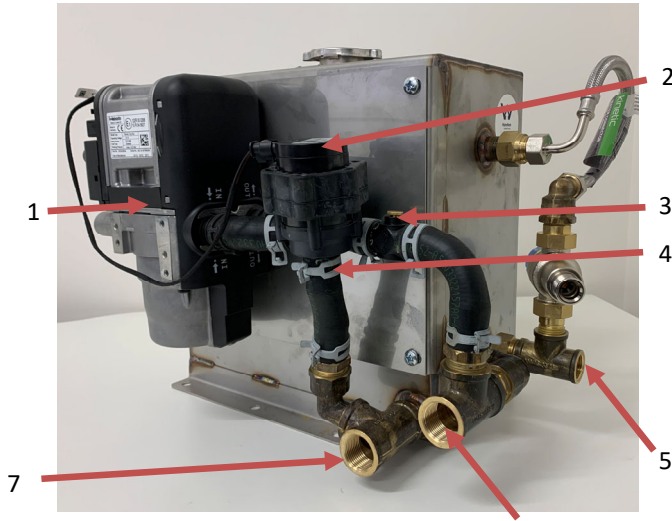

Fig 5 – Heater component location

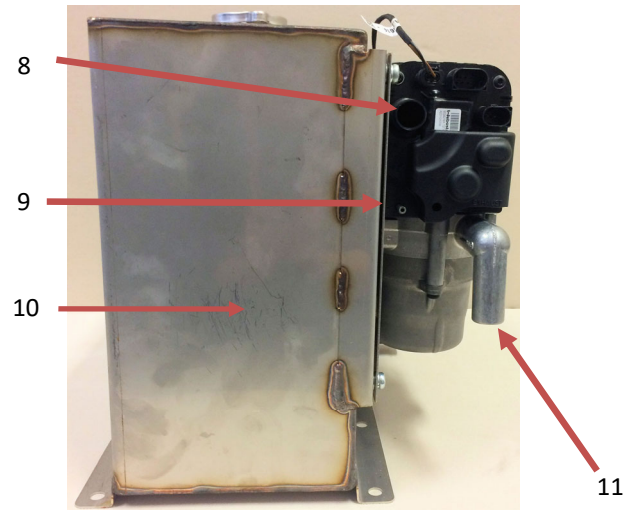

Fig 6 – Exhaust and Fuel Connection

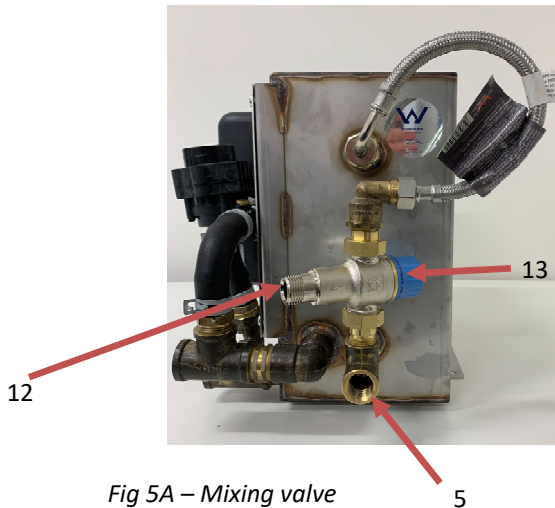

Fig 5A – Mixing valve



Fig 6A—Mixing Valve
(Set up mixing valve page 11)

ITEM	DESCRIPTION
1	DIESEL HEATER
2	CIRCULATION PUMP
3	COOLANT BLEED VALVE
4	CIRCULATION PUMP INLET
5	FRESH WATER INLET
6	RADIATOR FAN HEATER OUTLET
7	RADIATOR FAN HEATER INLET
8	COMBUSTION AIR INLET
9	FUEL CONNECTION
10	BUFFER TANK
11	EXHAUST OUTLET
12	HOT WATER OUTLET
13	MIXING VALVE

3. Step by Step Installation

- 3.1 Place the heater in your desired location to predetermine the position of the mounting holes, exhaust outlet, fuel line and electrical wiring.
- 3.2 Drill the 10mm mounting holes to secure the heater. When drilling the mounting holes, ensure that you allow clearance for chassis rails, water tanks, wiring harness etc. (Fixing hardware not supplied).
- 3.3 For the detailed electrical system see section 6, page 7.

4. Combustion Air

- 4.1 Connect the combustion air tube (Fig. 7) to the heater (Fig. 6) utilising the 25mm clamp.
- 4.2 Connect the combustion air silencer to the other end of the combustion air tube (Fig. 7)

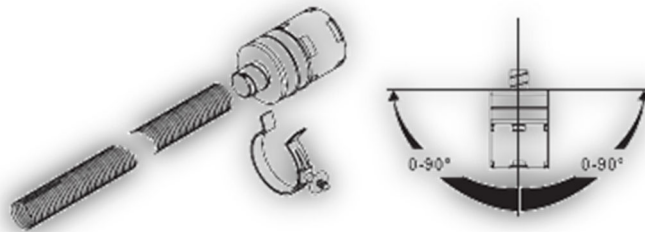

IMPORTANT! Fig 7 - Combustion filter, tube and clamps are all supplied in the kit.

The combustion air tube must be positioned in such a way that it cannot be obstructed by other objects.

Opening for combustion air must be located so that it cannot become clogged with dust and is protected from water ingress and located away from direct heat source.

Ensure that the hose clamps supplied in the kit are used.



IMPORTANT! Please note: It is the end-users responsibility to ensure that the combustion air tube silencer (end) is protected adequately to ensure no water ingress when crossing rivers etc.

5. Exhaust System

5.1 Install the stainless steel exhaust pipe using the 25mm exhaust clamps (as supplied) to the exhaust gas outlet (Fig. 6) (5). Webasto can supply exhaust lagging if required.

*The exhaust pipe temperature is above 250°C. Ensure that the end cap is properly mounted and pointing downwards. The exhaust **must not** point in the direction of travel. **The exhaust must be secured and away from heat sensitive components, vehicle fuel lines and harnesses.***

Note: *If the exhaust pipe is going through a wooden floor, Webasto can supply exhaust lagging if required.*

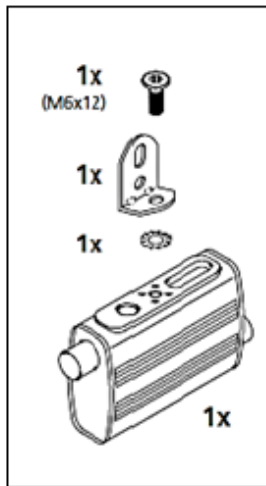

Fig 8 - Exhaust muffler is supplied in the kit. Mounting hardware with clamps and a bracket is supplied in the kit.



IMPORTANT!

Please note: It is the end-user's responsibility to ensure that the exhaust outlet (end) is protected adequately to ensure no water ingress when crossing rivers etc. and when travelling in dusty environments.

6. Electrical System

6.1 Wiring Harness (Plug & Play)



Fig 9 - Main Wiring Harness. All connections are labelled for ease of installation.

ITEM	DESCRIPTION
1	BATTERY POSITIVE (RED) (Fig 13)
2	BATTERY NEGATIVE (BROWN) (Fig 13)
3	CONTROLLER PLUG (Fig 11)
4	HEATER PLUGS (Fig 15)
5	FUSE BLOCK
6	FUEL PUMP PLUG (Fig 14)
7	COMPUTER DIAGNOSTIC CONNECTION



IMPORTANT! Ensure that plug 7 is accessible for any diagnostic situation

6.2 Controller

The EVO5 Hydronic Heater can be operated with two different controllers.

6.2.1 Digital Multi Controller



Fig 10 – Digital Multi Controller

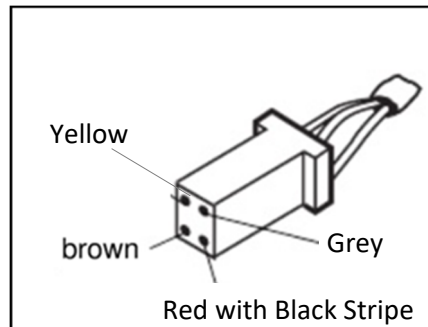

Fig 11 - 4 pin controller plug

The harness is supplied with a 4 pin timer plug for the multi-controller connection (Fig 10).

Note: Refer to page 16 for Digital Multi Controller user and set-up guide.

6.2.2 ON/OFF Switch

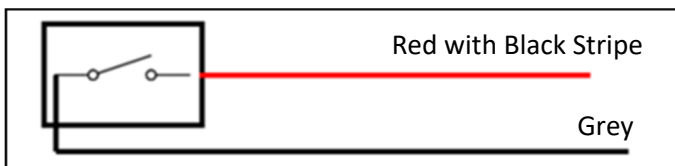

Fig 12 – On/Off Switch connection.

Note: The harness is supplied with a 4 pin plug for the connection to the Digital Multi Control (Fig 10). If the controller option is not used and an On/Off switch is used in its place (Fig 12), cut off the 4 pin plug (Fig 11) and connect a switch in between the red with black stripe and grey wire (Fig 12), the brown & yellow wires are not required.

6.2.3 FINSCAN Thermostatic Controller : Please refer to page 19 for user and set-up guide.

6.3 Battery Connections

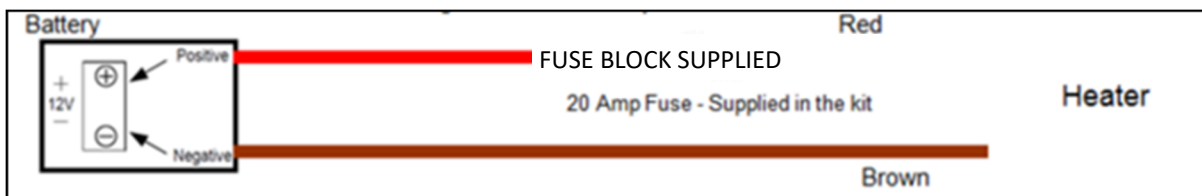

Fig 13 – Battery connection

Note: Ensure that the red positive and brown negative is connected directly to the house battery for correct shut down cycle, using the fuses supplied in the kit. (Fig 9, item 5)

20A Fuse for Heater (12V system)

1A Fuse for Digital Multi-Control



6.4 Fuel Wiring

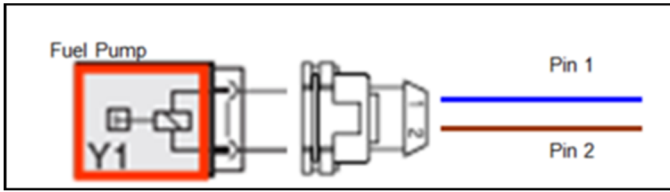

Fig 14 – Fuel pump connection

6.5 Heater Wiring (Main Plugs)

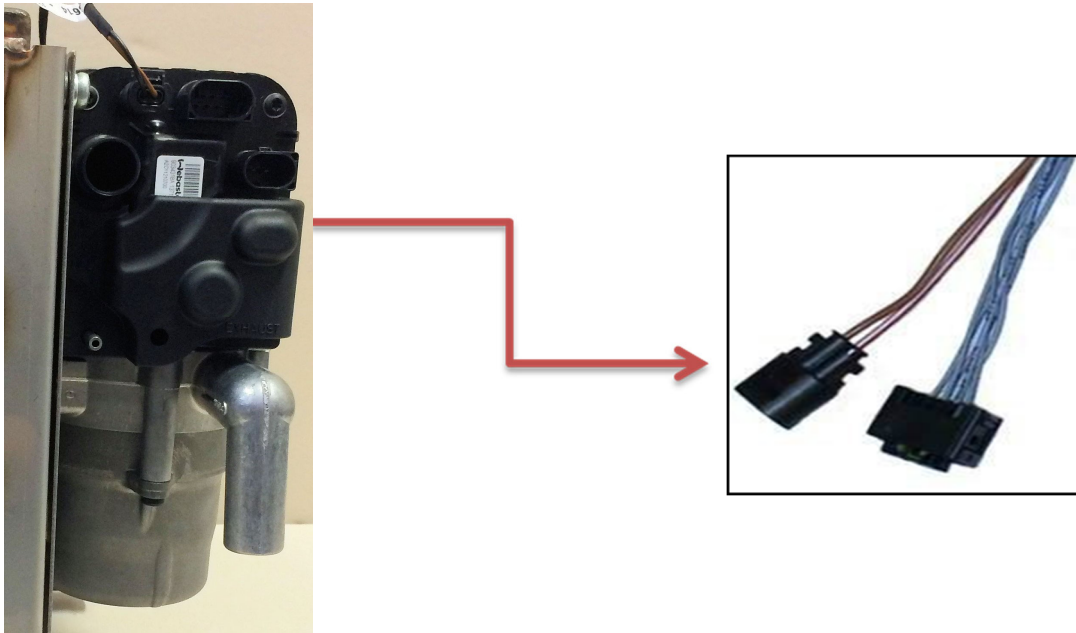

Fig 15 – Main plugs to the heater

The specific wiring harness is supplied in the kit with all connections. The wiring harness is play & plug. The main plugs connect, to the side of the heater and they can only connect one way. Ensure the plugs are pushed in all the way and “home”.

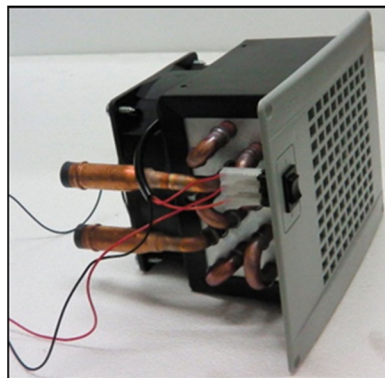

Fig 16– Wiring for the radiator fan heater.

Connect the red wire from heater switch to 12V positive and the black wire to negative. The heater is fitted with a two speed fan switch.

7. Fuel System

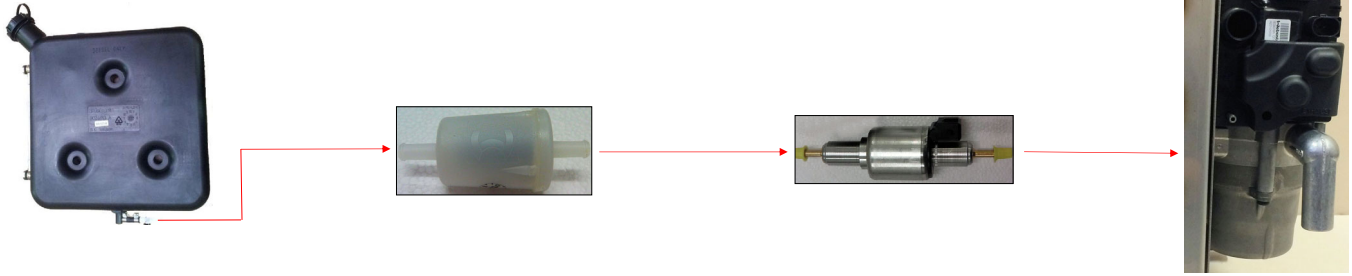

Fig 17 The kit is supplied with fuel pump, fuel filter, fuel line connections, hose clamp and 6m of fuel line. Follow the direction of flow as indicated on the fuel pump and the fuel filter.

7.1 Fuel Pump Rubber Mount



Fig 18 – Fuel pump, rubber mount and hardware supplied in the kit.

7.2 Installation - Fuel Pump

Ensure that the fuel pump is installed with the vibration rubber mount supplied in the kit. This will help reduce resonance through the vehicle (Fig. 19).

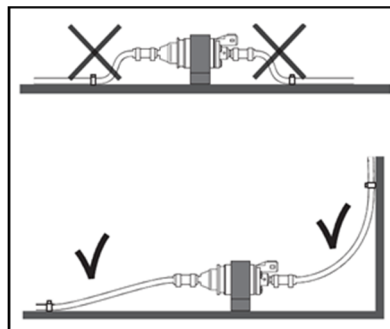

Fig 19 Fuel pump installed with vibration rubber mount

8. Mixing Valve

The mixing valve (Fig 5A) (12) is located at the hot water outlet on the tank. The user will achieve the desired water temperature by turning the knob on top of the valve (Fig 21) in the desired direction (clockwise or anticlockwise) in order to obtain water temperature between 38°C-55°C with a tolerance of $\pm 7^{\circ}\text{C}$.

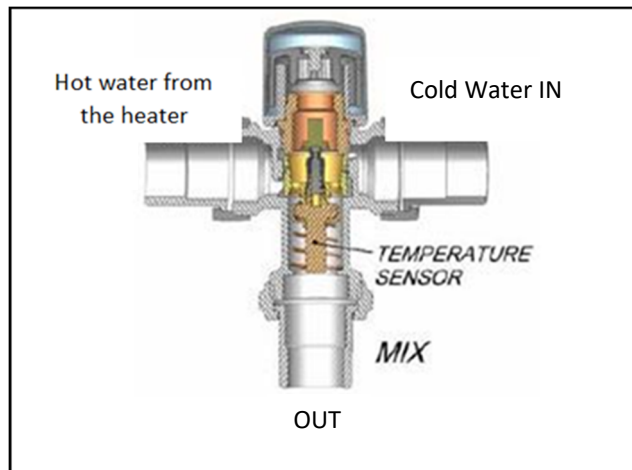

Fig 20 – Webasto mixing valve



CHARACTERISTICS OF THERMOSTATIC MIXING VALVE	
TEMPERATURE RANGE	38-55°C $\pm 7^{\circ}\text{C}$
FLOW RATE	1 BAR / 1.3 L/h
MAXIMUM TEMPERATURE	110°C
MAXIMUM PRESSURE	10 BAR / 145 psi
W	Hot Water In
BV	Hot Water out
KV	Cold Water In

Fig 21 – Webasto mixing valve, the mixing valve is fully installed ready to connect to the water circuit.



A mixing valve should be installed to avoid scolding

9. Water Circuit

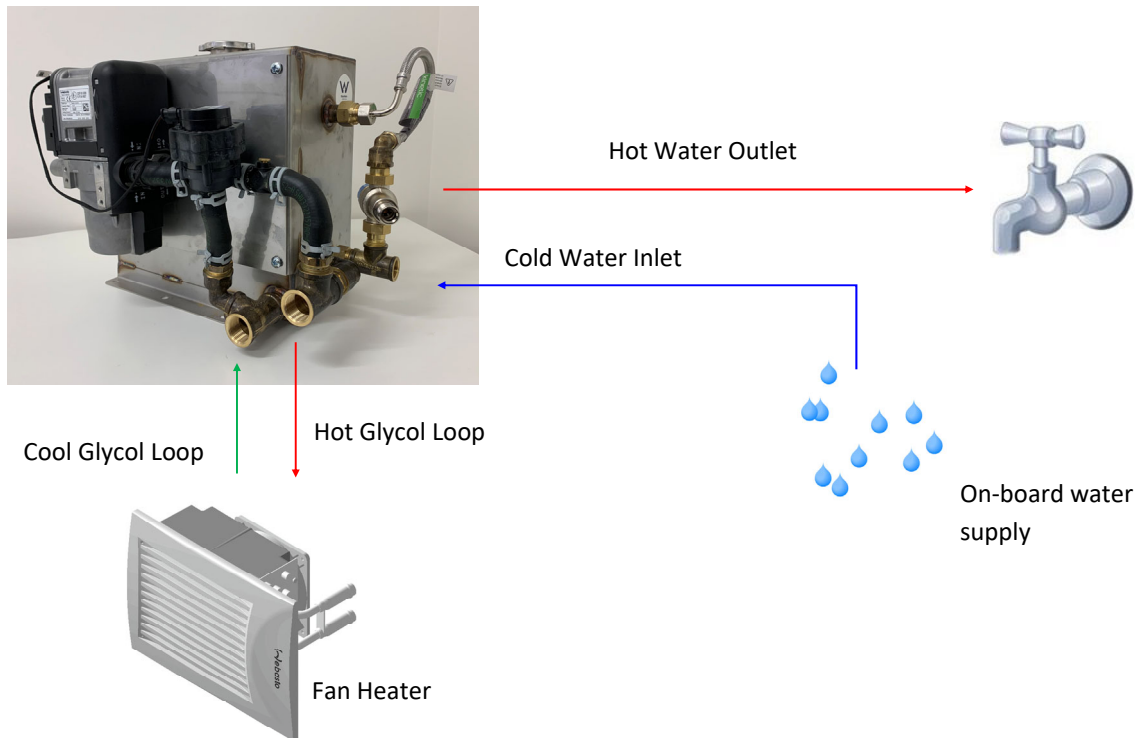

Fig 22 – Cold and hot water circuit. (Ensure that the maximum flow rate is 10L /min)

10. Radiator Air Fan Heater Circuit - Option

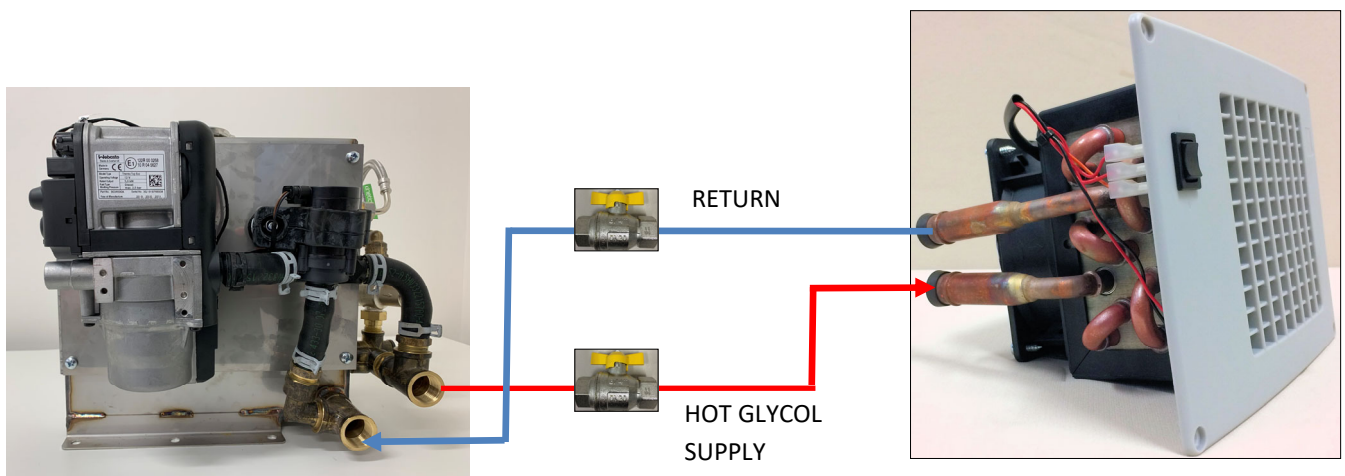

Fig 23 The kit is supplied with brass ball valves, during the summer season the ball valves can be shut off to avoid any radiant heat passing in to the cabin.

Remove the plugs on the inlet and outlet of the radiator fan heater before installing the hoses. Heater Mounting Cutout: 195 x 135 mm (L x H) x 170 mm depth clearance. The air fan heater can be mounted down on the kickboard or side of the cabinet, or as low as possible. Maximum length of the coolant hose is 3 meters.

The kit is supplied with 3m of insulated 3/4 rubber hose. Ensure that there is a consistent flow of coolant to the radiator fan heater and avoid any kinks on the line, as it will create restrictions and will affect the operations.

11. Coolant Line Bleeding

1. Ensure all coolant lines & connections are secure & properly sealed.
2. Where ball valves are fitted for the air heater, ensure they are open.
3. Fill the 15L buffer tank with coolant mixture; 2 parts glycol to 1 part water (10 L Glycol, 5 L Water) . (Standard glycol sold at any auto parts retailer). Fill to underside of filler neck.
4. Check system for any leaks and rectify.
5. Keep radiator cap off.
6. Where ball valves are fitted for the air heater, ensure these are now closed/shut.
7. Now open bleed valve (Fig. 22) by screwing the brass bleed screw (Fig. 23) anti-clockwise, NOTE do not remove the bleed screw completely.
8. Now turn the diesel hot water service on, refer Section 12, page 14 for start-up sequence.
9. Where fitted with ball valves, slowly open the supply valve and then slowly open the return valve.
10. Keep a watch on the bleed valve, after some time it should stop venting air bubbles and a small flow of coolant will be present, at this time close the bleed valve, turn clock-wise until tight.

⚠ WARNING *The coolant & tank may be hot, please take all necessary precautions to avoid scolding or injury.*

11. Allow the heater to operate for 2-3 more minutes ensuring no problems occur regarding the coolant circulation pump.
12. Turn of heater and allow system to cool.
13. Check coolant level & top up if necessary, fit radiator cap.
14. Check for any leaks & rectify.

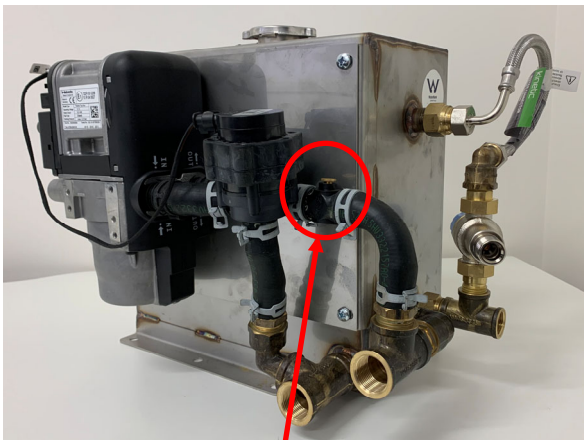

Fig. 24a Coolant line bleed valve



Fig. 24b Valve brass bleed screw

12. Start-up Sequence: Starting the Heater for the very first time

1. Ensure that the heater is bolted and secured.
2. Ensure all electrical wiring is connected and secured.
3. Ensure that the combustion air tube and silencer are connected.
4. Ensure the exhaust is connected.
5. Ensure all water hoses are connected and secured.
6. Test for any water leaks by pressurising the water system via the vehicle water pump.
7. If a radiator fan heater is connected ensure that the coolant lines are connected and secured.
8. Check there are no kinks on the coolant lines.
9. Ensure that the fuel line and fuel pump are connected and secured.
10. Fill the 15L buffer tank with coolant mixture; 2 parts glycol to 1 part water (10 L Glycol, 5 L Water) . (Standard glycol sold at any auto parts retailer).
11. Ensure all fuel connections and clamps are connected and secured.
12. Fill up the fuel tank.
13. If Radiator Air heater option is being used, open the brass ball valves.
14. Ensure that the battery connections are connected and secured.
15. Ensure the fuses is installed. (Check amperage 20A).
16. Bleed the fuel system. (See Section 13 for Fuel Line bleeding).
17. To allow full functional test of the heater (hot water & air) run the heater for at least an hour.

13. Fuel Line Bleeding Tip

Turn the heater on and with the start-up sequence, the process of the fuel pump will operate. During this operation fuel will be delivered to the heater. Depending on the length of the fuel line this may take a few attempts.

During the process the heater will try to start twice and if the fuel has not being delivered, it will enter in to a fault mode.

You will need to reset the heater by following the reset procedure in section 16.

14. Operation

The EVO5 Hydronic heater can be installed in a wide range of applications. This is a drop in solution designed by Webasto Thermo & Comfort Australia to minimize the installation time for the manufacturer and optimize the heating system. To meet the high quality standards of Webasto products, only qualified and authorized installers are allowed to perform the installation. The EVO5 Hydronic system designed by Webasto Australia has a 15L stainless steel glycol tank. The glycol used for the system is standard glycol used in automotive industry sold at any service station or auto parts retailer. The ratio of glycol used is 2:1—10 L glycol and 5 L water.

14.1 Switching ON

The heater is simply designed to turn on via the controller and is thermostatically controlled. The coolant circulation pump, glow plug and combustion air fan starts operation and after approximately 60 seconds combustion starts (audible combustion sound). After the coolant has reached the set point of 80°C the heater will automatically adjust its heat output to a lower operation range (partial heat load output). When the temperature of the coolant continues to rise and climb to 90°C at the heater outlet, the heater will cycle off. When the coolant temperature falls below 70°C the heater will restart and repeat the heating cycle. On initial start-up it will take approx. 15-20 mins to heat the coolant to around 90°C.

14.1.1 Radiator Fan Heater (Cabin Heating Option)

- Turn the cabin heater onto high fan speed.
- The cabin heater is now consuming energy from the coolant and will produce 60°C of hot air.

14.1.2 Hot Water

Adjust the tempering valve half way between maximum hot and maximum cold (half turn)
Turn the water pump on and adjust the tempering valve to obtain the desired outlet temperature.
(Cold water inlet temperature, will affect the hot water output temperature)
Refer Section 8 for the operation of mixing valve.

14.2 Switching OFF

When heating is no longer required, switch the heater off by the means of the ON/OFF toggle switch, digital multi-control or the timer option on the multi-control unit. Never turn off the heater by the main power supply. The combustion will be extinguished, followed by a shutdown cooling cycle of approximately 90 seconds.

14.3 Digital Multi-Controller User and Set-up

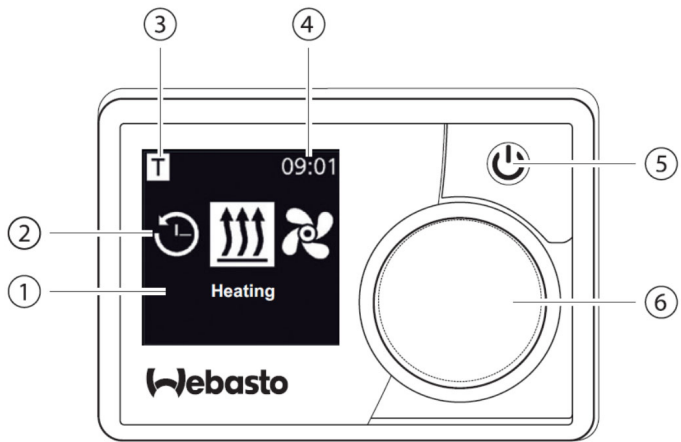

- 1 Menu Name
- 2 Menu Symbols
- 3 Time Setting Activated
- 4 Time
- 5 On / Off Button
RED LED—Fault
WHITE LED—Off
GREEN LED—On
- 6 Control Knob



Timer



Heating



Settings

Initial Start-Up

When the Control unit is connected for the first time, a message about the Setting/Configuration of the heater is displayed.



Press the control knob and the On/Off Button simultaneously for 3 seconds

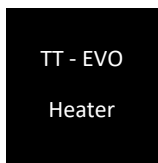

Select your Heater (Note: EVO5 Hydronic System is displayed as TT - EVO)

Press the Control Knob



Select the current Day

Press the Control Knob

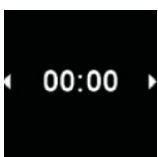

Select the current Time - turn the Control Knob clockwise to select Hour, press the Control Knob to confirm, then turn the Control Knob clockwise again to select the Minutes, press the Control Knob to set.

Press the Control Knob

If your heater was not selected correctly at Initial Start-Up a Manual Reset is required.

Press the On/Off Button to go to the Main Menu Screen and follow the following steps.

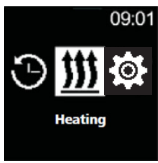

Select the symbol "Settings"

Press the Control Knob

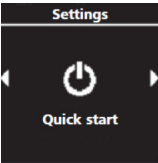

The "Quick Start" menu is displayed

Turn the Control Knob clockwise 10 times until "Reset" is displayed

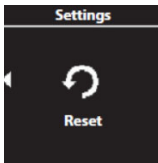

Select "Reset" by pressing the Control Knob

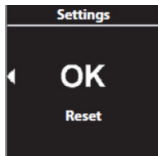

Press the Control Knob to confirm.

The Control Knob is now restarted

During the restart of the Control Knob, an Hourglass will quickly appear



Press the Control Knob and the On/Off Button simultaneously for 3 seconds

The Control is now ready for use.

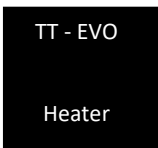

Select your Heater (Note: EVO5 HYDRONIC System is displayed as TT - EVO)

Press the Control Knob

Operation

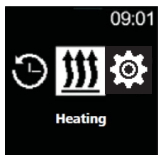

Select "Heating"

Press the Control Knob



Press the Control Knob to select continuous (infinite) running.

(OR To program a Timer at this point turn the Control Knob clockwise to select the time from 10 minutes to 2 hours).



Continuous (Infinite) Running has been selected

Timer Set-up

It is possible to program the Timer Setting 7 days in advance. The heater switches on automatically at the programmed time. Up to 3 time settings per day can be set, with a total of 21 time settings for the week.

Before the timer can be activated, make sure that the:

- Time and current day of the week are set,
- Heater is switched off

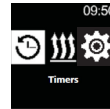

Press the Control Knob

“Add Timer” screen is displayed

Press the Control Knob in order to add a new timer

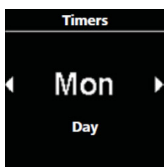

Turn the Control Knob to select chosen “Day”

Press the Control Knob to confirm selection

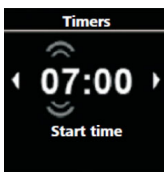

Turn the Control Knob to choose the desired Switch On time (Hour)

Press the Control Knob to confirm

Turn the Control Knob again to choose the Minutes

Press the Control Knob to confirm

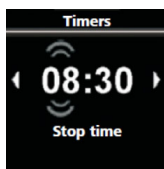

Turn the Control Knob to choose the desired Switch OFF time (Hour)

Press the Control Knob to confirm

Turn the Control Knob again to choose the Minutes

Press the Control Knob to confirm

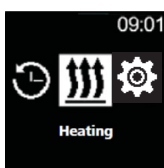

Select the “Heating” operation mode from the Main Menu screen

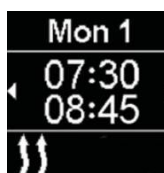

The programmed timer is saved and shown on the display



Press the Control Knob to activate the programmed time

“Activate” message will appear on the display

Repeat the process to add timers (3 timer settings per day, 21 per week)

14.4 Finscan Thermostat Digital Controller

Component Dimensions:

Control Box

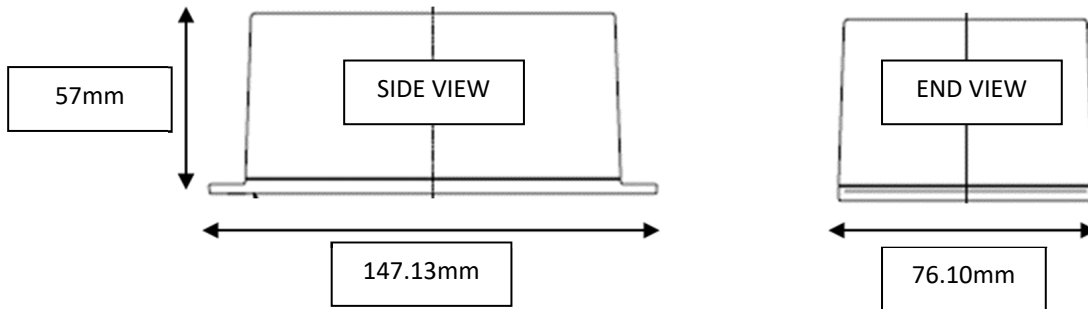

Touch Screen

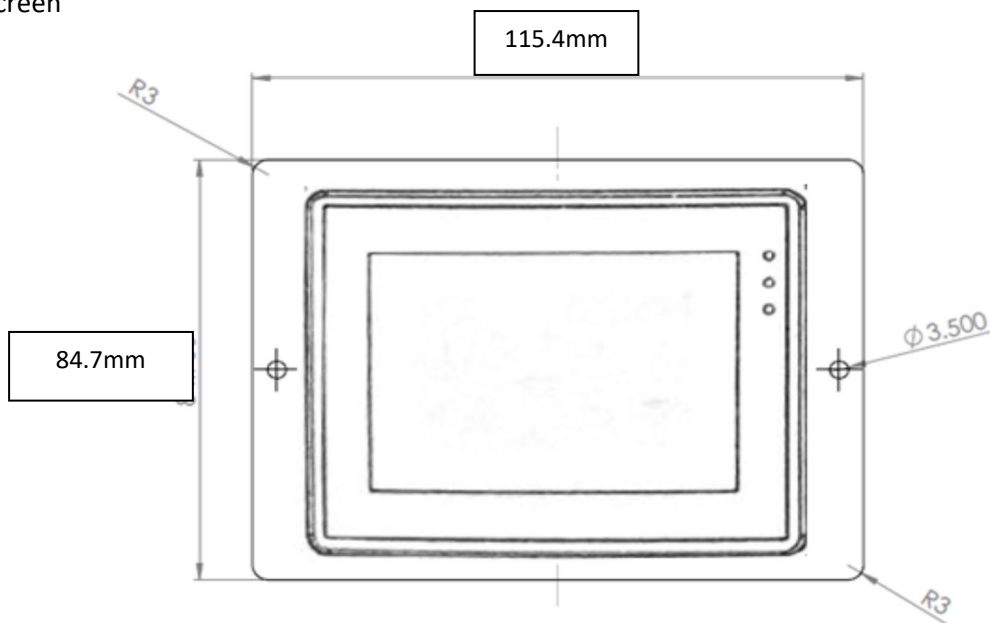
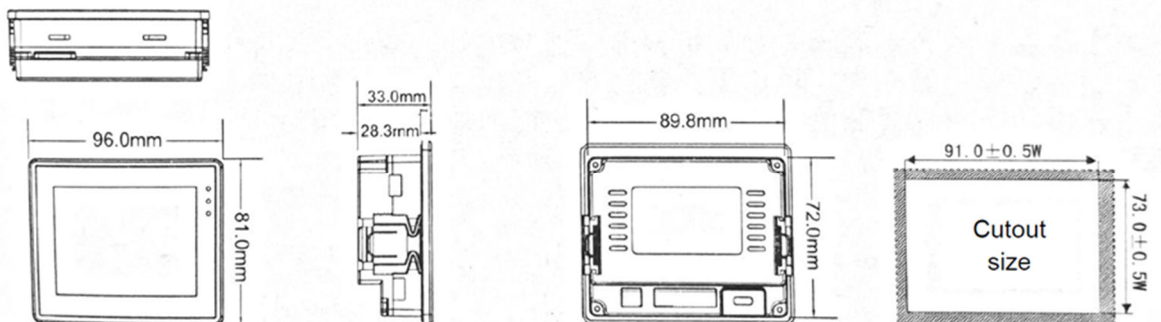

Fig. 25 Touch screen dimensions



Connections:

Finscan controller wiring



Fig. 26 Control box wiring connections

12V (+): Power supply for the control box.

Ground (-): Negative power supply connection for the control box and black negative wire from fan

Heating (12V) = 12V signal is supplied to this output when heating button is pressed. Cut the 4-pin plug from the heater main harness; connect the grey wire here.

High Speed Fan: Red wire from the air heater for high speed fan operation.

Medium Speed Fan: Orange wire from (3-speed fan) air heater for medium speed fan operation.

Note: Do not connect when using a 2-speed fan

Low Speed Fan: Yellow wire (3-speed fan) or Orange wire (2-speed) from the air heater for low speed fan operation.

Screen Data Cable: The blue CAT5 data cable with an RJ45 connector plugs into the back of the screen, standard 3m length supplied.

* Note: Maximum 4A current draw for all connections, ensure to use 3mm² cable for fan connections

Temperature Sensor:

The twin core cable (grey and grey w/ black stripe) connects to the temperature sensor supplied in the kit a 2-pin plug is attached to the temperature sensor harness. Not polarity sensitive.

The temperature sensor should be placed in a location that is at approximate chest height of a standing person to achieve the most suitable temperature comfort. Do not install the temperature sensor in direct path of air heater or other source of heat, such as stove or direct sunlight.

Finscan Bypass:

In case of troubleshooting or an error with the *Finscan* controller, the *Finscan* control box can be bypassed by use of a bridging wire between “Heating (12V)” and “12V (+)” on the control box.

System Layout & Components:

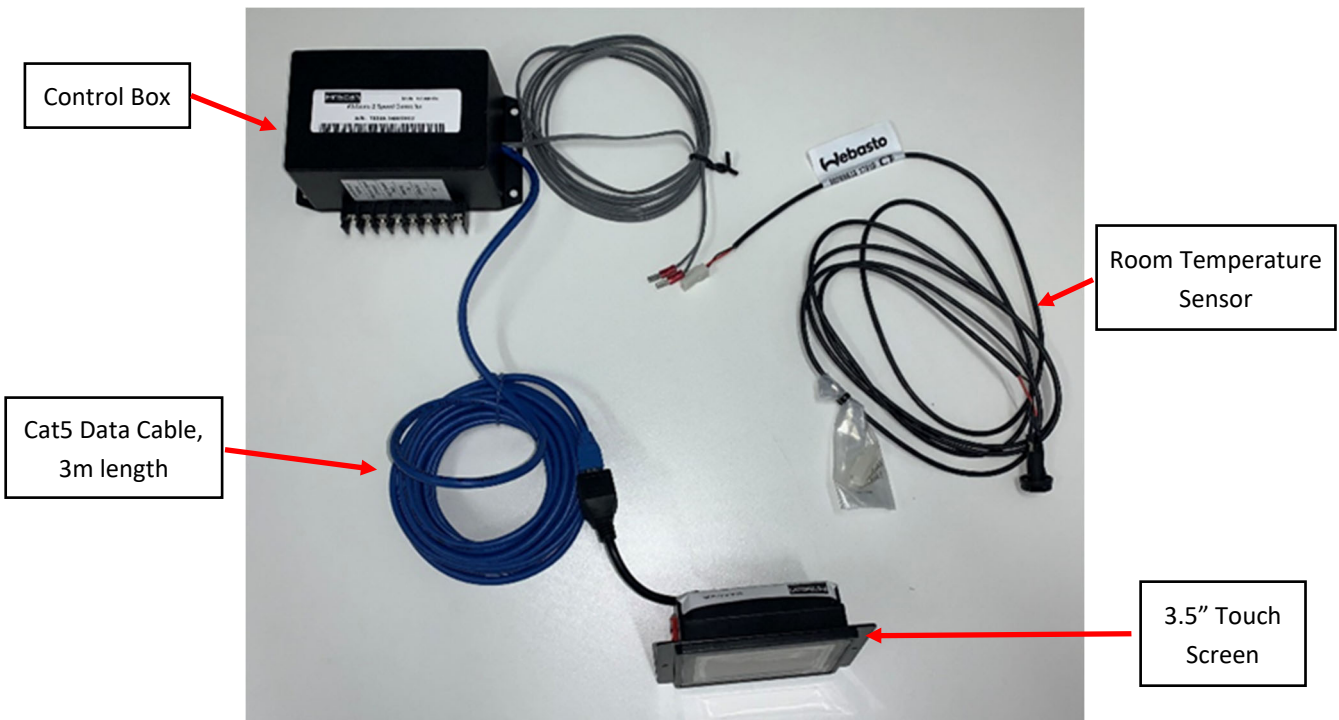
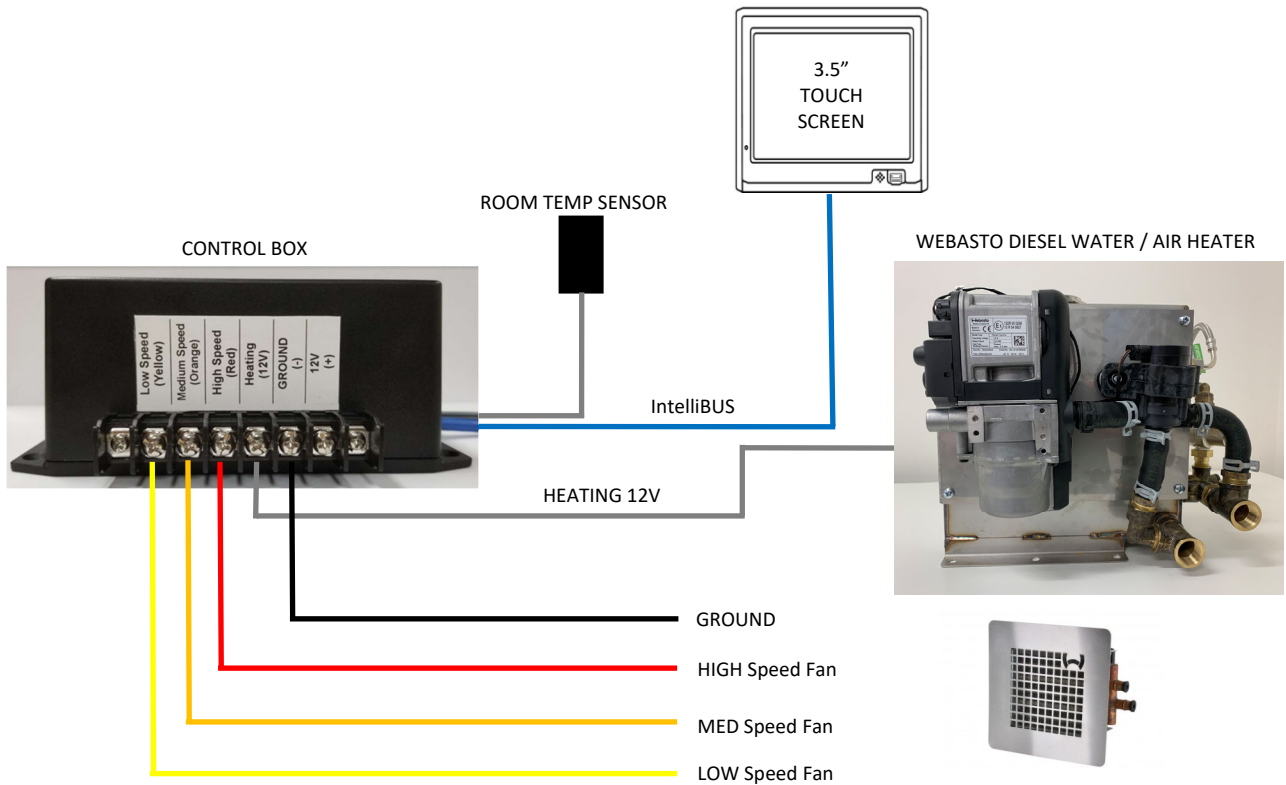

Fig. 27 Finscan control components

Operation:

The controller has two modes of operation, Auto and Manual modes.

Auto Mode: This mode allows a user to set the temperature on screen. The system will automatically turn on the burner for heating, and adjust fan speed to heat the cabin air. As the temperature climbs in the cabin, the fan speed will be adjusted automatically to maintain the set temperature. There is no further input required from the user, apart from adjusting the temperature to a different temperature.

Note: Auto mode will turn on the heating output for burner operation automatically, but will not turn it off. This will need to be turned off manually from the Manual mode screen.

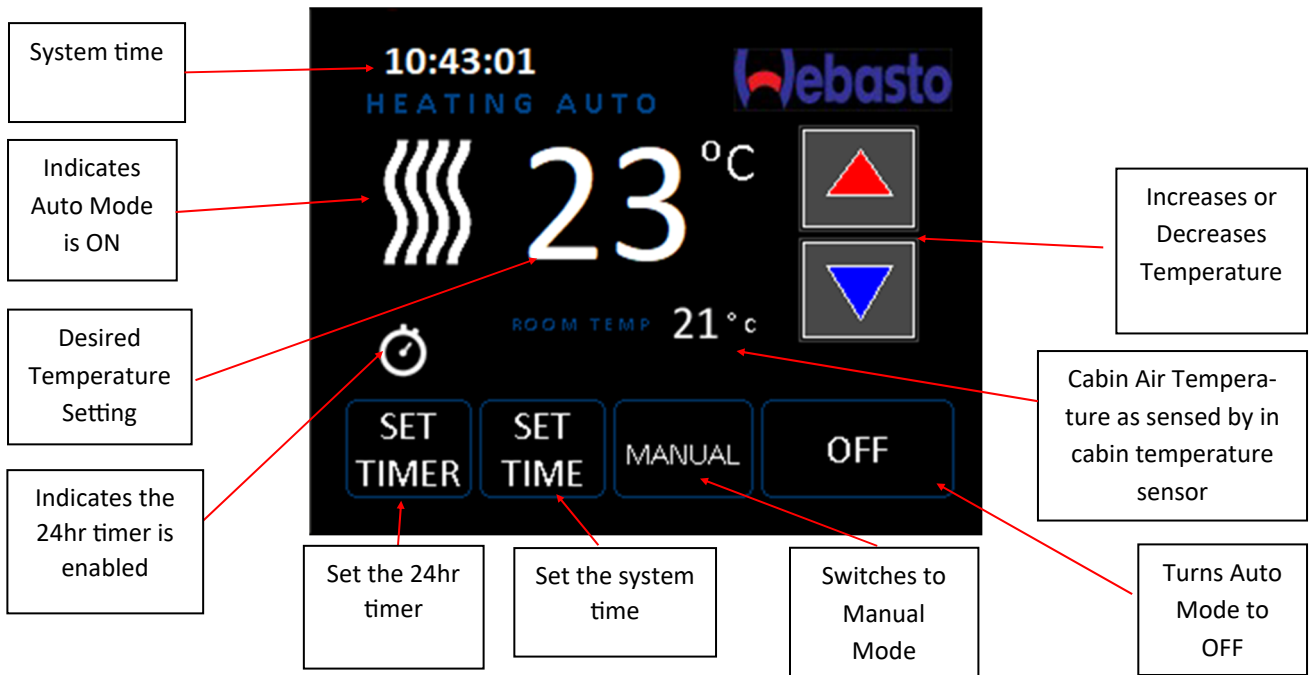

Manual mode: This mode will allow individual operation of fan speed and heating. Manual mode will also allow operation of fan for ventilation, with heating output turned off. This mode is entirely manual and will require the user to adjust fan speeds and heating.

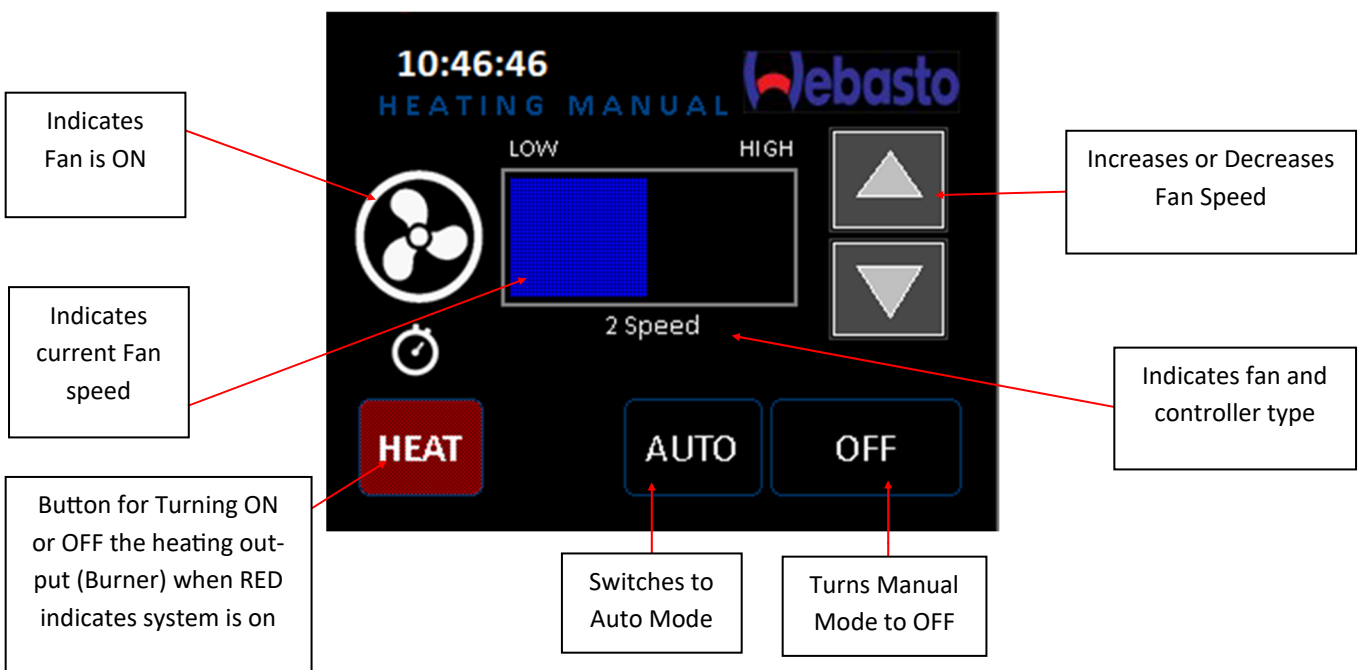

SET SYSTEM TIME:

System clock is in 24hr time. To set the clock, press the system time button on the AUTO page.

Then press the hours, minute or seconds box to adjust time.

Note: This will only adjust the selected box (such as hours or minutes)

An on screen keypad will pop up and allow entry of a new time value. Press ENT to confirm.

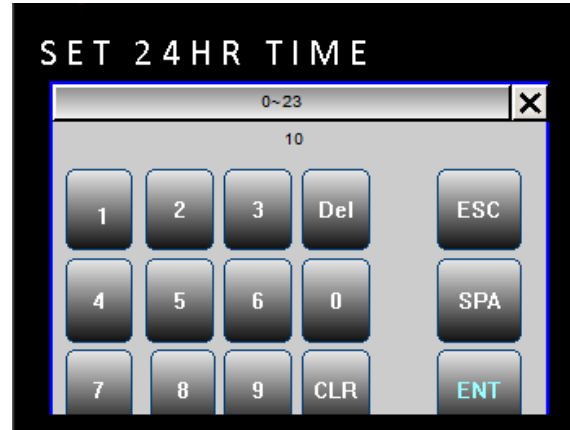
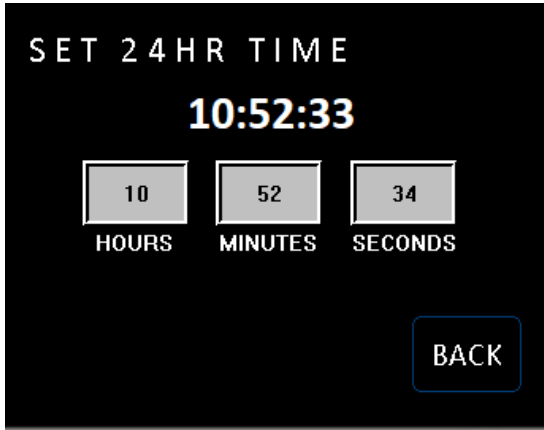

SET TIMER:

The Set timer function allows the operator to set a specific time for the system to turn on in Auto mode, the temperature will be set at the last desired temperature that AUTO mode was set to.

To set the START and END times , press the SET TIMER button on the AUTO page.

When the HOURS or MINUTES box is pressed, an on screen keypad will pop up and allow entry of a new value. Press ENT to confirm.

Then press the TIMER RUN button to activate the timer, this button highlights blue (indicating that TIMER is running). A small clock icon will appear on the AUTO and MANUAL pages indicating that the timer is running and AUTO mode will turn on and off at the set times daily.

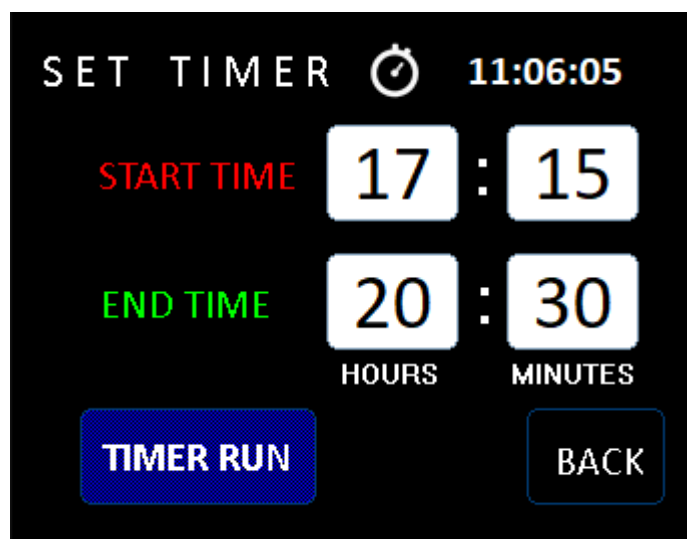

To deactivate the timer, return to the SET TIMER page and press the TIMER RUN button, the blue highlight will turn off.

15. Preventative Maintenance

The heater requires minimum maintenance to keep it in good operating condition:

1. Clean the heater compartment from any accumulated debris or dust.
2. Inspect all components for wear and damage
3. Check air intake and exhaust for any restriction.
4. Check fuel line for damage, restriction, kinks or loose connections
5. Inspect all coolant lines and clamps for leakage or damage
6. Check water coolant and fuel connections for leaks, tighten hose clamps if necessary.
7. Check glycol level, top up if necessary. (Standard glycol sold at any auto parts retail store).
8. Ensure to run the heater for an hour every month regardless of the season.



IMPORTANT!

Note: The build up of Carbon is not a warrantable condition
Situations in which carbon could build up in the heater are:

- Under Voltage: the system should have at least 12.5-13V for proper operation
- Low current: the system requires 7-8A for the initial start-up phase for 120 seconds and once the flame is established the glow plug goes out and continues running at 2-3A.
- Under size wire: ensure that correct wire size is used for battery connections if there was any extension made to the existing cables supplied.
- Fuel system: bad quality fuel, air pockets in the fuel line or running out of fuel.
- Combustion system: any blockage or restriction in the combustion air tube or at the silencer.
- Exhaust system: any blockage or restriction in the exhaust muffler or pipe.
- Isolation switch or circuit breaker: can prevent the heater from performing a correct shut down cycle. The battery positive & negative wire should to be connected directly to the battery.
- Poor electrical connections such as, improper crimping of terminals or plugs not connected fully etc.

16. Reset Procedure

Permanent lock out (H87) reset procedure for Thermo Top EVO5

Note: *When using the digital multi-control and the H87 error displays, press the control knob to acknowledge the error*

1. Turn off the heater using either controller or switch
2. Remove 20A Fuse
3. Wait 30 seconds and then refit 20A Fuse
4. Wait 30 seconds
5. Turn Heater on using controller/switch & then remove 20A fuse between 3 and 10 Seconds
6. Wait 30 seconds and then refit 20A Fuse
7. Turn off the heater using controller/switch
8. Wait 30 seconds
9. Turn Heater on - procedure complete



H87 error displayed on multi-control only

17. Trouble Shooting Guide

FAILURE SYMPTOMS	PROBABLE CAUSE	REMEDY
Coolant heater switches off automatically	No combustion after start or automatic restart	Switch off heater momentarily and switch on once again
Heater expels black smoke from exhaust	Combustion air and/or exhaust ducting blocked	Check combustion and exhaust ducting for obstructions. If the smoking does not clear after 30mins of running, perform troubleshooting by a Webasto authorised dealer.
Heater will not start at all	Low battery voltage Low current draw	Check battery voltage (12-13.5 V) Check electrical connections Check fuse (20amps) Check current draw (Initial Start-up 6-7amps) Once the flame is established 2-3 amps continues running
Heater will start up then shut down after few minutes	Low battery voltage Low current draw Air pockets in fuel line Air pockets in glycol line	See above for low battery voltage & current For air pocket in the fuel or glycol line, bleed the system. For bleeding process: Fuel System – while the heater is running check the fuel pulse and look for air pockets in the clear fuel line. The fuel connection on the heater can be removed to let air out. Glycol Line – Run the heater, while the circulation pump is running, release one of the rubber hose clamps to bleed the system.
Heater will start up and shut down after few minutes	Heater overheats	Check coolant level Coolant system needs to be bled No Circulation Check coolant lines for obstruction, for closed valves and kinks. Allow heater to cool down, reset overheat limiter, perform the rest procedure and switch on once again to test.
Low Coolant level	Standard coolant used in automotive industry (Purchased at any auto parts retailer)	The glycol tank has a capacity of 15 litres. 10 Litres of glycol and 5 Litres of water. Periodical check are important it is no different to the system in your car or motorhome.
<p>For any of the troubleshooting listed above, if you are not sure please do not attempt, as there is hot glycol up to 90°C which can cause bodily harm if safety precautions are not taken.</p> <p>In any case, if you are unsure please contact your nearest Webasto Authorised dealer for further advice.</p>		

18. Fault Codes

Fault codes as displayed on the digital multi-control

Fault code	Fault Description	Recommended Checks
HA9	Insufficient coolant flow	<ol style="list-style-type: none"> 1) Check coolant system for leaks 2) Check circulation pump is operating 3) Bleed coolant circuit - Page 13
H0B	Circulation pump short circuit	<ol style="list-style-type: none"> 1) Inspect cabling between the ECU connection & the circulation pump
H1B	Overheat sensor short circuit	<ol style="list-style-type: none"> 1) Inspect cabling between the ECU connection & the temperature sensor 2) Perform reset procedure - Refer to Section 16 3) If it is a Defective Control Unit - H01 fault code will be displayed
H02	No start	<ol style="list-style-type: none"> 1) Check air intake & exhaust system are free from obstructions and blockages 2) Check fuel system is free from air pockets and fuel is reaching the heater 3) Feel the fuel pump is pulsing 4) Check electrical system - no blown fuses and all plugs on main wiring harness are plug in with a solid connection
H06	Heating unit overheated	<ol style="list-style-type: none"> 1) Perform reset procedure - Refer to Section 16 2) Check coolant level 3) Bleed coolant circuit - Page 13
H08	Fuel pump short circuit	<ol style="list-style-type: none"> 1) Inspect main wiring harness to fuel pump for cable damage 2) Perform reset procedure - Refer to Section 16
T12	W bus communication failure	<ol style="list-style-type: none"> 1) Check voltage at main plug into heater is greater than 11.5V 2) Check main fuses ensuring the fuses are in correct position / not blown 3) Check the main plugs into the heater are in correctly 4) If fault code persists contact authorised Webasto dealer
15	Combustion air fan blocked	<ol style="list-style-type: none"> 1) Check combustion air & exhaust system are free from blockages or obstructions
84	Operating voltage too low	<ol style="list-style-type: none"> 1) Check voltage at main plug into heater is greater than 11.5V 2) Conduct check of battery connections
86	Excessive water temperature without combustion process	<ol style="list-style-type: none"> 1) Troubleshooting in coolant system and bleed system (Bleed coolant circuit - Page 13) 2) If fault code persists contact authorised Webasto dealer
87	Heater lock-out permanent	<ol style="list-style-type: none"> 1) Perform reset procedure—Refer to Section 16
92	Command refresh failure	<ol style="list-style-type: none"> 1) allow heater to finish shutdown cycle before attempting a restart 2) If fault code persists contact authorised Webasto dealer

Webasto's Authorised Service & Repair Network

NSW	A-ONE Caravan Repairs 146 Macpherson Road LONDONDERRY 2753	(02) 4572 7176
	Irwin's Outdoors 431 Thirlmere Way THIRLMERE 2572	0417 250 369
	Newcastle Caravan Repairs 63 Pendlebury Road CARDIFF 2285	(02) 4956 6036
	Premium Caravan & Motorhome Services Unit 4, 25-31 Airds Road MINTO	0404 121 925
	RVGO Unit H, 26-30 Tepko Road TERREY HILLS 2084	(02) 9986 2952
	Wagga Car Radio 379 Edward Street WAGGA WAGGA 2650	(02) 6925 6111
	Advantage Caravan Repairs 23 Thornycroft Street CAMPBELLFIELD 3061	(03) 8339 0772
	Albury Wodonga RV World 1A Watson Street WODONGA 3690	(02) 6024 4222
VIC	Cool Factor 5/314 Governor Road BRAESIDE 3195	(03) 9587 5244
	Retro Looms 42 Renver Road CLAYTON 3168	(03) 8521 3021
	Caravan and RV Works 12-14 Enterprise Street KUNDA PARK 4556	(07) 5445 6662
QLD	VanGo Caravan Services 1/74 Perrin Drive UNDERWOOD 4119	(07) 3209 5044
	Roof Rack City 37 Gilbert Street ADELAIDE 5000	(08) 8211 7600
WA	The Camper Tamperer Bunbury	0416 173 515
	Perth Mobile Caravan Service & Repair Perth Metro	0419 912 198
TAS	TAS Mobile Caravan Service 83 Meander Valley Road WESTBURY 7303	0458 615 003
ACT	Technic Trims and Sunroof 2/1 Sawmill Circuit, Hume ACT	(02) 6260 2587

Notes



Notes



Notes





Webasto Thermo & Comfort Australia Pty Ltd
423-427 The Boulevard, Kirrawee NSW 2232 Australia

Ph: +61 (0)2 8536 4800

svc-info@webasto.com
www.webasto.com

